

4 MISCS 6288M1

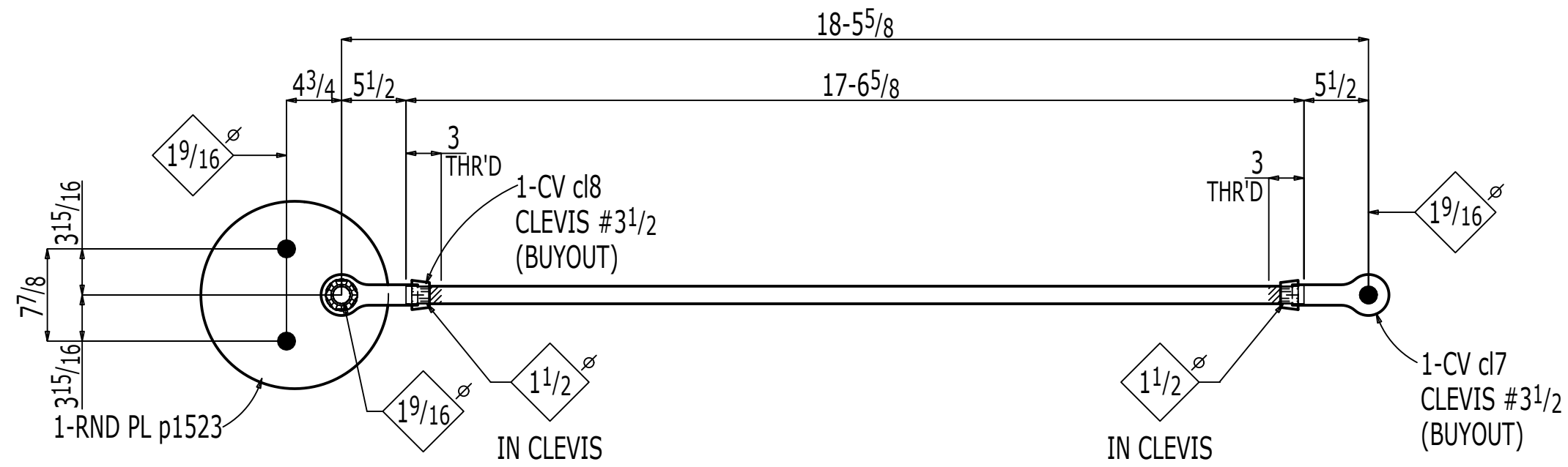

2 MISCS 6288M2

SHOP BOLTS:
1-TC 1 1/2x3 1/2 A325N

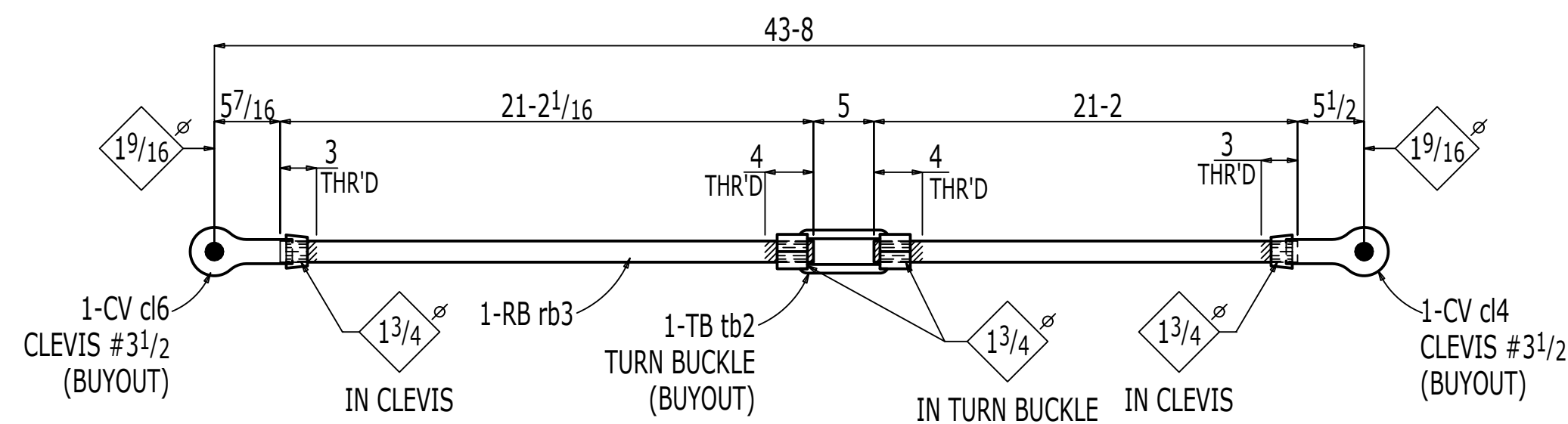

ONE MISC 6288M3

BILL OF MATERIAL

SEQUENCE	QTY	DESCRIPTION	LENGTH	MARK	GRADE	REMARKS	ADVANCE
QTY							MILL #
4	4	MISC		6288M1		NO PAINT	
	4	RB1 1/2	21 6	6288M1	A572-50		
	4	CLEVIS #3 1/2	0 6	cl7		BUYOUT	
	4	CLEVIS #3 1/2	0 6	cl8		BUYOUT	
		FIELD BOLTS					
	8	TC 1 1/2 Dia A325N	0 3 1/2				
2	2	MISC		6288M2		NO PAINT	
	2	RB1 1/2	17 6 5/8	6288M2	A572-50		
	2	CLEVIS #3 1/2	0 6	cl7		BUYOUT	
	2	CLEVIS #3 1/2	0 6	cl8		BUYOUT	
	2	PL3/4x16		p1523	A572-50		
	2	TC 1 1/2 Dia A325N	0 3 1/2				
		FIELD BOLTS					
	2	TC 1 1/2 Dia A325N	0 3 1/2				
1	ONE	MISC		6288M3		NO PAINT	
	1	RB1 3/4	21 2	6288M3	A572-50		
	1	TB1 3/4x6	0 11	tb2		BUYOUT	
	1	CLEVIS #3 1/2	0 5 15/16	cl4		BUYOUT	
	1	CLEVIS #3 1/2	0 5 15/16	cl6		BUYOUT	
	1	RB1 3/4	21 2 1/16	rb3	A572-50		
		FIELD BOLTS					
	2	TC 1 1/2 Dia A325N	0 3 1/2				

ISSUE/REVISIONS	REV	BY	DATE	DESCRIPTION

MATERIALS:	STRUCTURE:		
	LOCATION:		
	ARCHITECT:		
	ENGINEER:		
PAIN:	CUSTOMER:		
D.F.T.:	DRAFTER:	SHOP ORDER	SHEET NO. REV
CLEANING:			
REF:	HOLES: 13/16" Ø UNO	CHECKER:	